

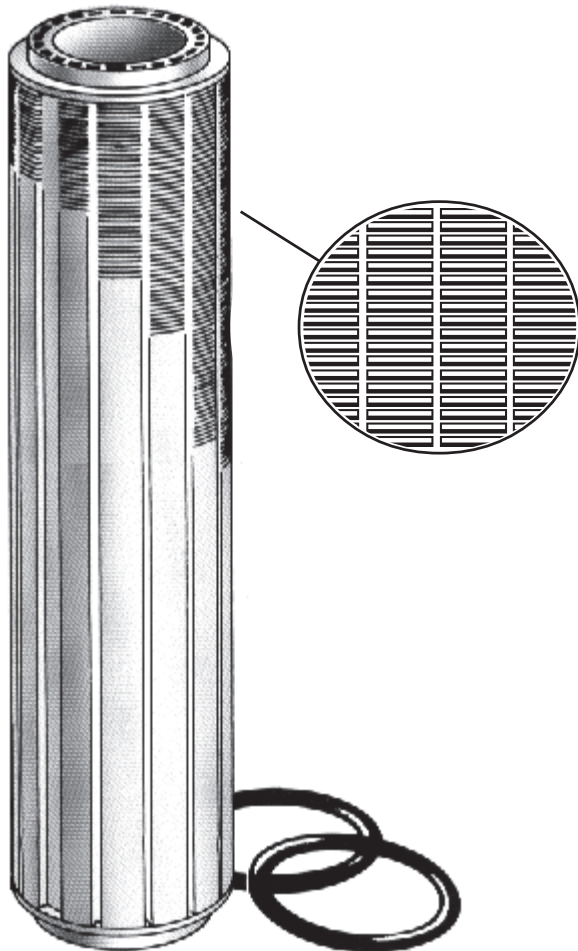

LAMINOVA

OIL TO WATER HEAT EXCHANGERS





- ◆ *High heat transfer- three times higher than conventional exchangers.*
- ◆ *Low pressure drop- advanced flow pattern allows full heat dissipation while sacrificing a minimum of pressure.*
- ◆ *No solder joints- o-rings seal the two piece modular design instead of stacks of pipes and plates.*



Laminova Heat Exchangers

The Laminova heat exchanger consists primarily of two pieces of extruded aluminum profiles, the core and the shell. The inner surface of the core is optimized for efficient water flow rates, low pressure drop and minimum risk of fouling. The outer surface of the core is optimized for maximum liquid (oil) to surface contact, laminar flow, low pressure drop and high heat transfer. The assembly of both sections is sealed with o-rings, ensuring that the unit is resistant to vibration and pressure pulsation.

Laminova Theory

The Laminova concept can be best described as an almost infinite number of interconnected laminar cooling fins. Each fin is 3mm in height by only 0.2mm thick. The oil flow gap between the fins is 0.3mm. By this arrangement the oil flow is continuously interrupted and restarted after an optimized flow length. Normally such restrictive finning would cause a huge pressure drop, but by introducing channels in the finning, the oil is kept laminar (as opposed to turbulent as in other cooler designs) and pressure drop remains low.

Laminova Application

Ideally, all engine water (coolant) should pass through the unit. If this is not possible a partial flow may be obtained by teeing off and running in parallel with the water radiator/heater core. In this case we can supply a partial restrictor or plug to divert more water through the annular water ducts in the core. This will restrict the overall flow of water in the main cooling system and is more likely to be beneficial in partial flow installations. We suggest experimenting with restrictors only when more cooling is required. Oil flow to the unit may be obtained by using a take off plate between the engine block and filter or plumbing in with the remote filter or drysump circuit. BAT stocks a large selection of MOCAL oil plumbing components for ease of installation. In application Laminova coolers offer real advantages in ease of installation where space is limited, also the cooler does not consume precious under hood air flow and their robust construction protects from oil leakage and possible fire in crash situations. The modular construction allows for easy disassembly for cleaning or service.

Recommended Sizing

It is difficult to come up with meaningful "real world" performance figures as these are dependent on oil and water flow and size and efficiency of the water radiator as variables. In application we have found that a Laminova 90mm (small) core will perform similar to a typical 10 to 13 row air to air 235 matrix cooler, a 180mm (medium) to a 16 to 19 row and 330mm (large) to a 25 to 30 row.

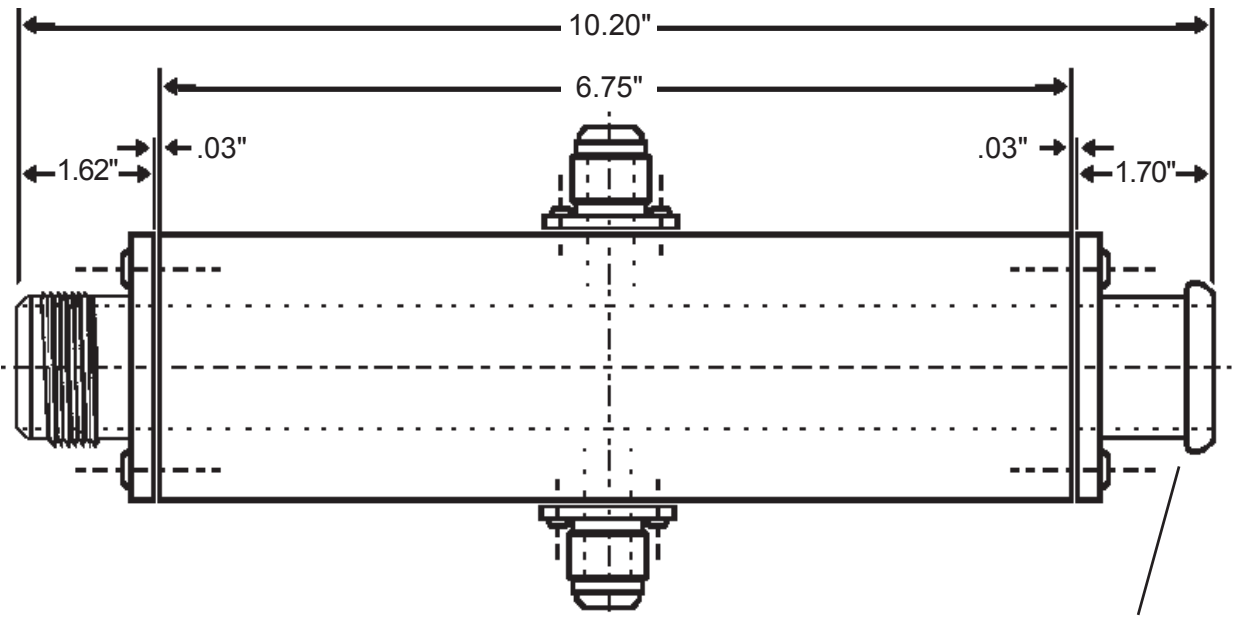

waterside fittings push-on
(5/8", 3/4" 1.10", 1.25", 1.50" 1.75")

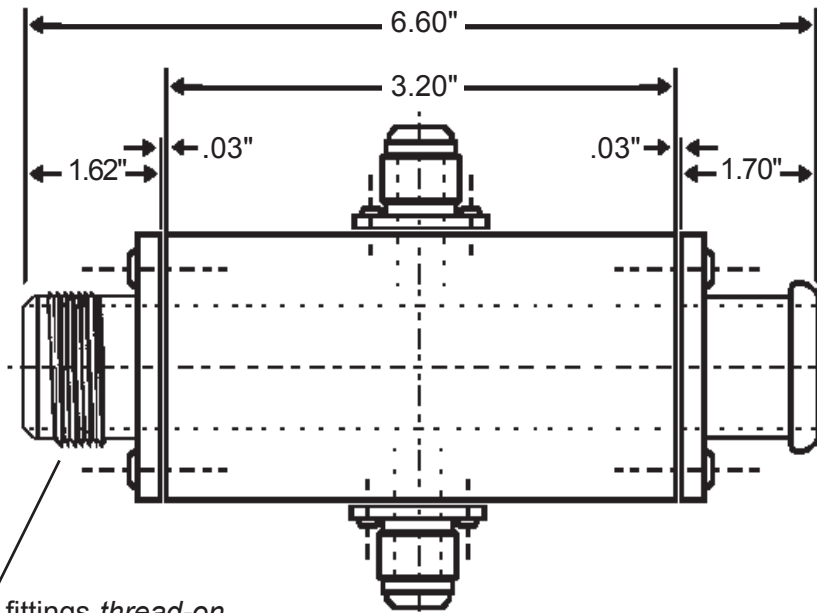
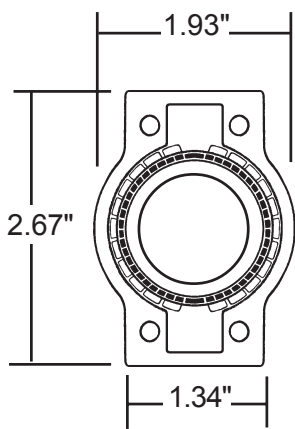

waterside fittings *thread-on*
(-16AN, -20AN, -24AN / JIC)

oilside flange fittings *thread-on*
(-8AN, -10AN, -12AN, -16AN / JIC)

C43 Series Heat Exchangers

A43-180 Cooler (top)

A43-90 Cooler (bottom)



thread-on waterside fittings
(-16AN, -20AN, -24AN / JIC)

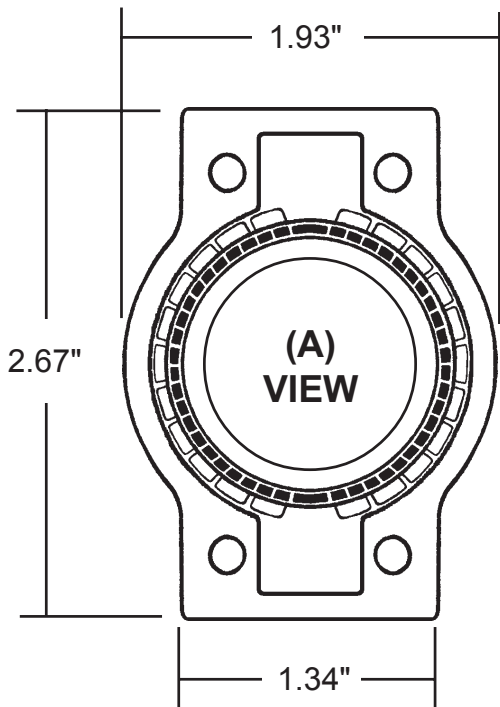

thread-on oilside fittings
(-8AN, -10AN, -12AN, -16AN / JIC)

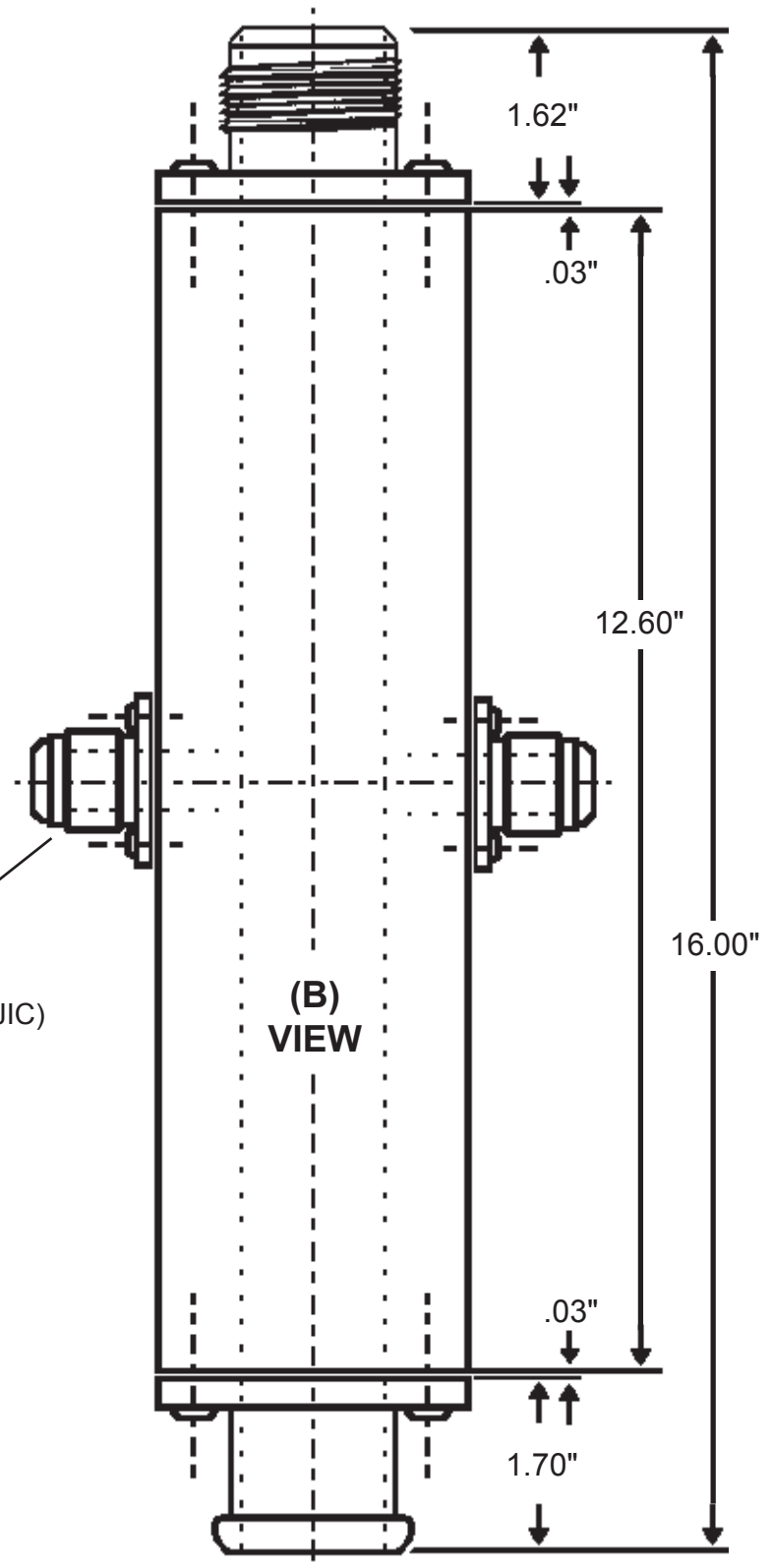

push-on waterside fittings
(5/8", 3/4" 1.10", 1.25", 1.50" 1.75")

C43 Series Heat Exchangers

Cooler Cutaway (A View) same all sizes

A43-330 Cooler (B View)

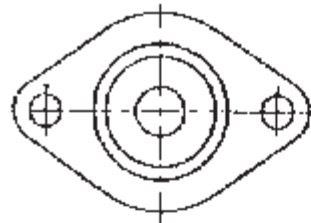

UNF 9/16"-18

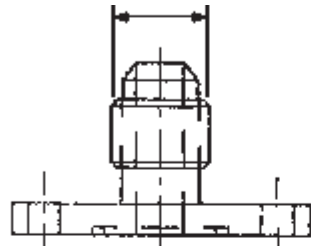

JIC 6 (-6AN)

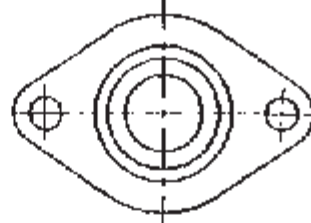

UNF 3/4"-16

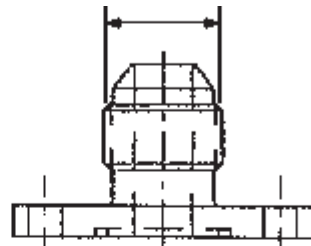

JIC 8 (-8AN)

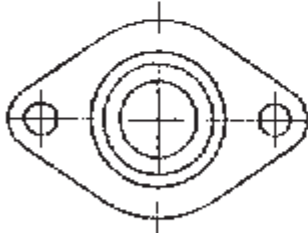

UNF 7/8"-14

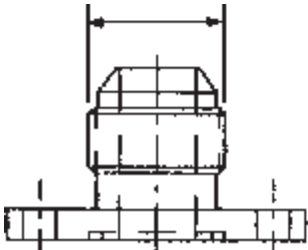

JIC 10 (-10AN)

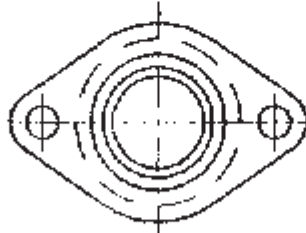

UNF 1 1/16"-12

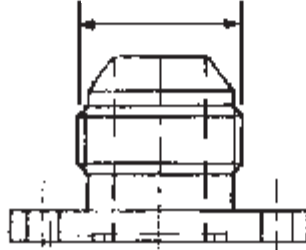

JIC 12 (-12AN)

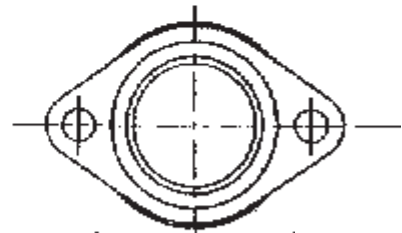

UNF 1 5/16"-12

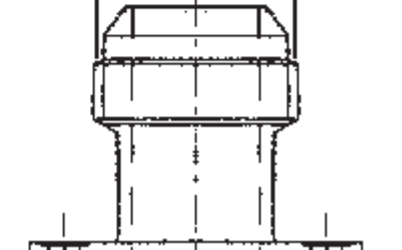

JIC 16 (-16AN)

Additional sizes: 1/2" push-on hose, -4AN/JIC, 3/4" BSP

C43 Series Oil Side Fittings

(top row) -6AN, -8AN

(bottom row) -10AN, -12AN, -16AN

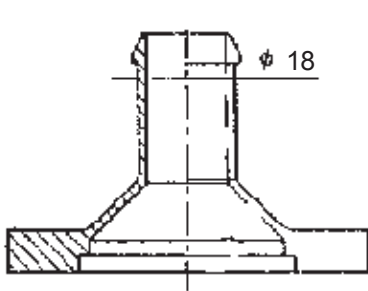

18mm (.70") push-on

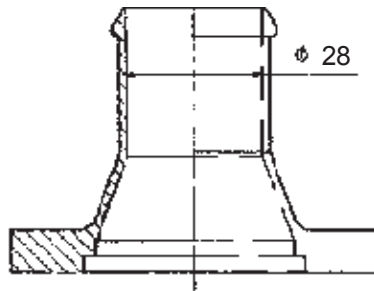

28mm (1.10") push-on

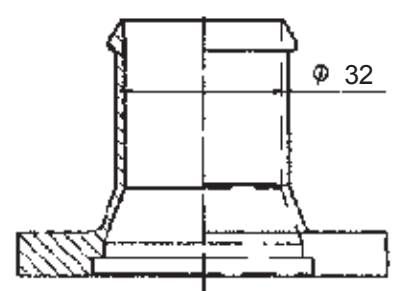

32mm (1.25") push-on

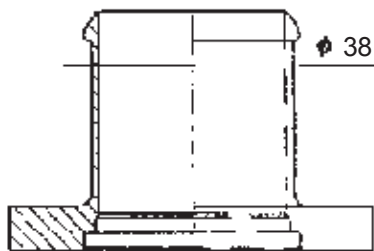
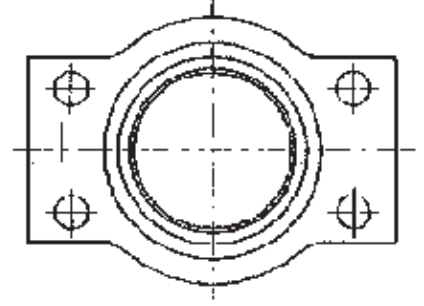
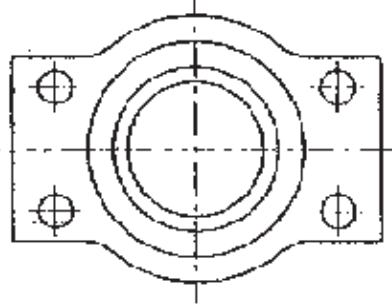
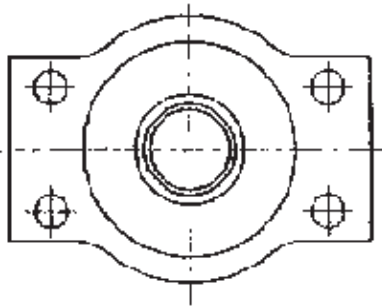

38mm (1.5") push-on

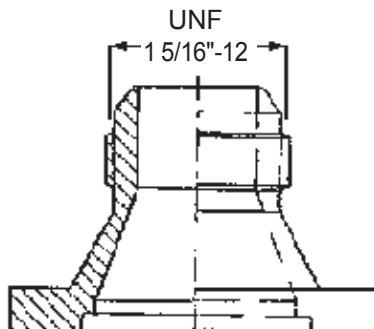

JIC 16 (-16AN) thread-on

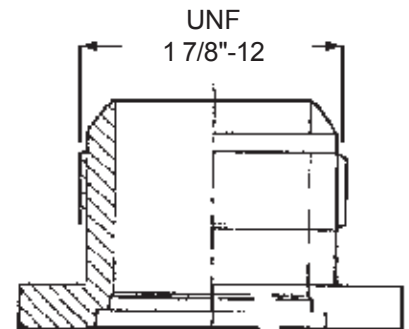

JIC 24 (-24AN) thread-on

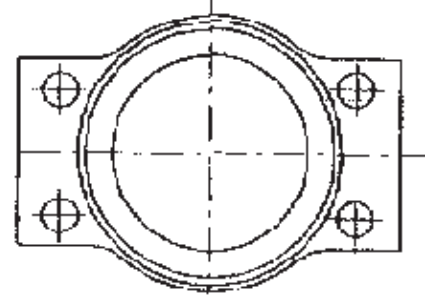
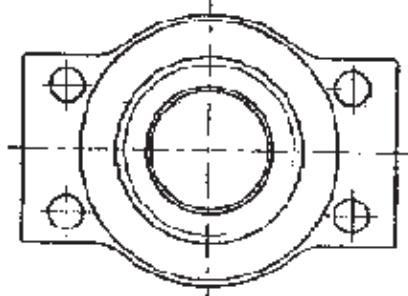
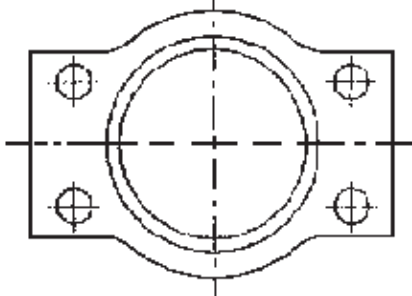

Additional sizes: (push-on hose) 16mm, 24mm, 35mm, 42mm, 45mm, (male thread) -20AN/JIC, 3/4" BSP, (female thread) 3/4" NPT.

C43 Series Water Side Fittings

(top row) 18mm, 28mm, 32mm

(bottom row) 38mm, -16AN, -24AN

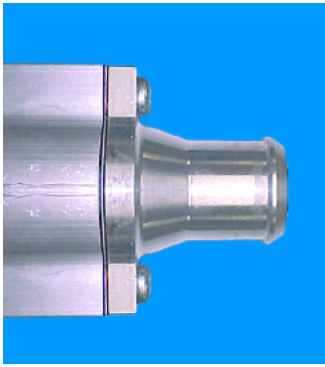

A43P cooler with push-on water end

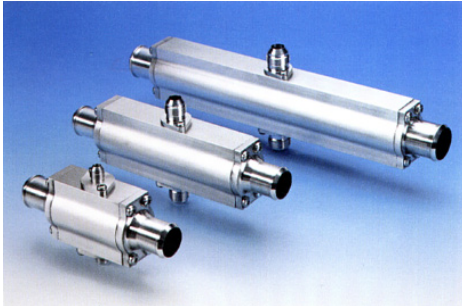

A43 Series Coolers - 90mm, 180mm & 330mm core sizes.



A43A cooler with thread-on water end

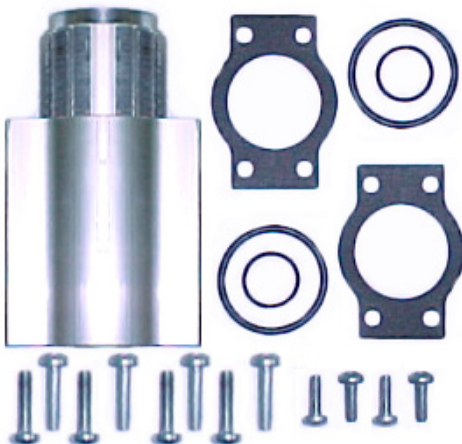

A43K (Build Kit) includes: core, housing, seals, gaskets & hardware.

Laminova C43-90 Series Heat Exchanger

A43-90P cooler with push-on water connections **\$309.55**
 (1) assembled 90mm core heat exchanger unit configured with your choice of (2) oil -6, -8, -10, -12 and (2) push-on water 16, 18, 24, 28, 32, 35, 38, 45mm fittings (excludes 90 degree version of 32mm).

A43-90A cooler with thread-on water connections **\$339.00**
 (1) assembled 90mm core heat exchanger unit configured with your choice of (2) oil -6, -8, -10, -12 and (2) thread-on water -16, -20, -24AN or 3/4" NPT female fittings.

A43-90K core, housing, seals, gaskets & hardware **\$215.70**
 main components - less water and oil connections - allows for custom build if optional specification fluid connections are required. See additional listing of oil and water fittings.

Click text in [BLUE](#) for technical drawing.

Laminova C43-180 Series Heat Exchanger

A43-180P cooler with push-on water connections **\$359.00**
 (1) assembled 180mm core heat exchanger unit configured with your choice of (2) oil -6, -8, -10, -12 and (2) push-on water 16, 18, 24, 28, 32, 35, 38, 45mm fittings (excludes 90 degree version of 32mm).

A43-180A cooler with thread-on water connections **\$389.00**
 (1) assembled 180mm core heat exchanger unit configured with your choice of (2) oil -6, -8, -10, -12 and (2) thread-on water -16, -20, -24AN or 3/4" NPT female fittings.

A43-180K core, housing, seals, gaskets & hardware **\$263.00**
 main component - less water and oil connections - allows for custom build if optional specification fluid connections are required. See additional listing of oil and water fittings.

Click text in [BLUE](#) for technical drawing.

Laminova C43-330 Series Heat Exchanger

A43-330P cooler with push-on water connections **\$490.00**
 (1) assembled 330mm core heat exchanger unit configured with your choice of (2) oil -6, -8, -10, -12 and (2) push-on water 16, 18, 24, 28, 32, 35, 38, 45mm fittings (excludes 90 degree version of 32mm).

A43-330A cooler with thread-on water connections **\$520.00**
 (1) assembled 330mm core heat exchanger unit configured with your choice of (2) oil -6, -8, -10, -12 and (2) thread-on water -16, -20, -24AN or 3/4" NPT female fittings.

A43-330K core, housing, seals, gaskets & hardware **\$347.60**
 main components - less water and oil connections - allows for custom build if optional specification fluid connections are required. See additional listing of oil and water fittings.

Click text in [BLUE](#) for technical drawing.





C43 water side fittings



C43 oil side fittings



C43 water restrictors



C43 gasket, seal & hardware kit

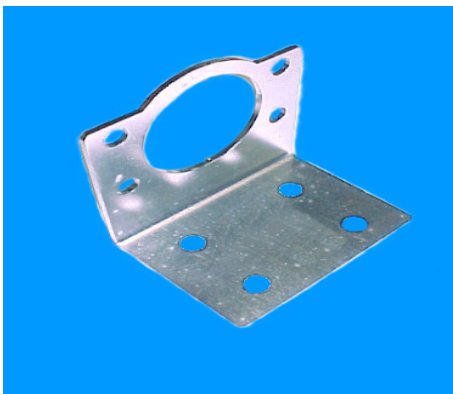

C43 mounting brackets

Net Price list



01/2017

Laminova C43 Water Side Fittings (each)

LWC-M16 16mm (.630") O.D. push-on hose	\$39.60
LWC-M18 18mm (.70") O.D. push-on hose	\$36.60
LWC-M24 24mm (.945") O.D. push-on hose	\$39.60
LWC-M28 28mm (1.10") O.D. push-on hose	\$39.60
LWC-M32 32mm (1.25") O.D. push-on hose	\$39.60
LWC-M32/90 32mm (1.25") O.D. push-on hose 90 degree	\$55.00
LWC-M35 35mm (1.38") O.D. push-on hose	\$39.60
LWC-M38 38mm (1.50") O.D. push-on hose	\$37.50
LWC-M42/90 42mm (1.65") O.D. push-on hose 90 degree	\$53.55
LWC-M45 45mm (1.77") O.D. push-on hose	\$37.50
LWC-N75 3/4" NPT female for union	\$39.60
LWC-A16 (-16AN/JIC) thread-on	\$59.40
LWC-A20 (-20AN/JIC) thread-on	\$68.00
LWC-A24 (-24AN/JIC) thread-on	\$68.00

Laminova C43 Oil Side Fittings (each)

LOC-4 -4AN fitting for thread-on hose ends	\$52.00
LOC-6 -6AN fitting for thread-on hose ends	\$24.20
LOC-8 -8AN fitting for thread-on hose ends	\$24.50
LOC-10 -10AN fitting for thread-on hose ends	\$21.70
LOC-12 -12AN fitting for thread-on hose ends	\$21.70
LOC-16 -16AN fitting for thread-on hose ends	\$44.00
LOC-B12 3/4" BSP" for thread-on hose ends	\$62.00
LOC-M14 M14 x 1.5 female for union or banjo bolt	\$38.00
LOC-P5 1/2" fitting for push-on hose	\$33.00
LOC-P62 5/8" fitting for push-on hose	\$33.00

C43 Water Restrictor & Plug (each)

TB00007 full restrictor/plug	\$9.05
TB00027 partial restrictor	\$5.95

Restrictors can be used to adjust overall cooler efficiency by regulating water flow to the core. Factors such as; water flow & temperature, oil flow & temperature, oil viscosity & volume, engine rpm, water radiator size & efficiency will also determine overall cooler performance.

C43 Gaskets, O-rings & Hardware (each)

LS-M5 oil side retaining screw (4x required)	.85
LS-M6 water side retaining screw (8x required)	1.25
L0-M18 18mm O-ring for oil side fittings (2x required)	\$1.30
L0-M36 36mm O-ring for water side fittings (2x required)	\$1.80
LWG-43 gasket between housing & water side ends (2x required)	\$4.15
UA00005* kit with all gaskets, o-rings & screws	\$24.50

*enough components to build one A43 cooler

C43 Mounting Brackets

A43-B1 mounting bracket (pair)	\$39.75
---------------------------------------	----------------

Note: Fitting with water ends larger than 38mm will require trimming brackets.

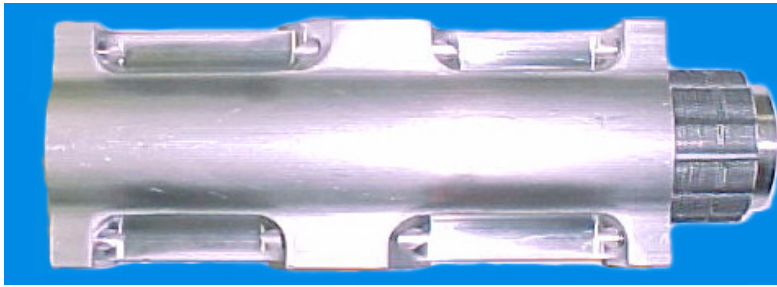

C45 Series Racelite Oil Cooler

The C45 series cooler is essentially an optimized C43 housing that has been lightened by removing any excess weight and bored out to receive an increased diameter 45mm (up from 43mm) core. Complete coolers (depending on size) are from 1/3 to 1 pound lighter and approximately 10 percent more efficient thanks to increased fin surface area. C45 units utilize standard C43 water and oil side fluid connections. When ordering, choose appropriate size fluid connections and match up with the C45 housing/core length of your choice. We are happy to provide assembled units at no additional charge - simply provide us the build specs when ordering.

Laminova C45 Series Racelite Kits

A45-90K core, housing, seals/gaskets & hardware **\$TBA**
 main components - less water and oil connections - allows for custom build if optional specification fluid connections are required. See additional listing of oil and water fittings.

A45-180K core, housing, seals/gaskets & hardware **\$390.35**
 main components - less water and oil connections - allows for custom build if optional specification fluid connections are required. See additional listing of oil and water fittings.

A45-330K core, housing, seals/gaskets & hardware **\$TBA**
 main components - less water and oil connections - allows for custom build if optional specification fluid connections are required. See additional listing of oil and water fittings.

C43/45 Water Side Fittings (each)

LWC-M16 16mm (.630") O.D. push-on	\$39.60
LWC-M18 18mm (.70") O.D. push-on	\$39.60
LWC-M24 24mm (.945") O.D. push-on	\$39.60
LWC-M28 28mm (1.10") O.D. push-on	\$39.60
LWC-M32 32mm (1.25") O.D. push-on	\$39.60
LWC-M32/90 32mm (1.25") O.D. push-on 90 degree	\$55.00
LWC-M35 35mm (1.38") O.D. push-on	\$39.60
LWC-M38 38mm (1.50") O.D. push-on	\$37.50
LWC-M42/90 42mm (1.65") O.D. push-on 90 degree	\$55.00
LWC-M45 45mm (1.77") O.D. push-on	\$37.50
LWC-N75 3/4" NPT for union	\$39.60
LWC-A16 -16AN/JIC thread-on	\$59.40
LWC-A20 -20AN/JIC thread-on	\$68.00
LWC-A24 -24AN/JIC thread-on	\$68.00

C43/45 Oil Side Fittings (each)

LOC-4 -4AN male fitting	\$52.00
LOC-6 -6AN male fitting	\$24.20
LOC-8 -8AN female fitting	\$24.50
LOC-10 -10AN male fitting	\$21.70
LOC-12 (-12AN male fitting	\$21.70
LOC-16 -16AN male fitting	\$44.00
LOC-B12 3/4" BSP" male fitting	\$62.00
LOC-P5 1/2" push-on hose	\$33.00
LOC-P62 5/8" push-on hose	\$33.00

C43/45 Water Restrictor & Plug (each)

TB00007 full restrictor/plug	\$9.05
TB00027 partial restrictor	\$5.95

C43/45 Mounting Bracket (pair)

A43-B1 stainless steel brackets	\$55.00
---------------------------------	---------



EC/ECD 54 Series Coolers

These compact, high performance, single and dual core design oil coolers are the choice for maximum heat transfer in motorsports and industrial vehicle service. Construction is similar to the popular C43 type coolers modular design which allows flexible configuration. Heat transfer of a E54 single core cooler is 25% greater than a similar length C43 cooler. The dual E54 cores are offer roughly 40% greater cooling over single core version and almost double the performance of similar length C43 cooler. E54 series coolers can be "stacked" for multiple cooling tasks: Engine and transmission cooler sections joined together as one unit.

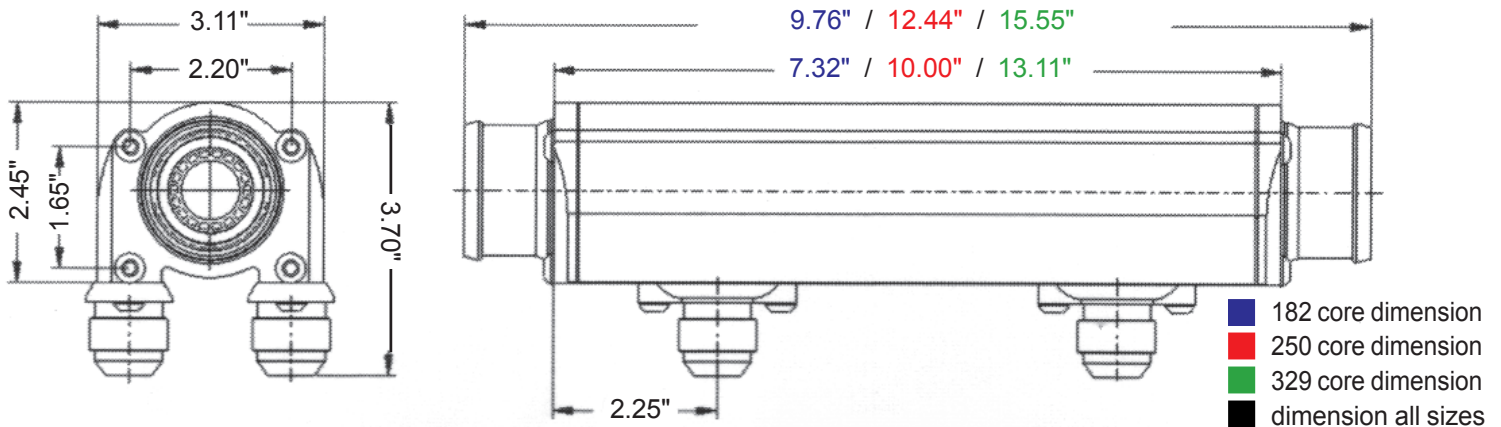

EC/ECD54 Series Advantages:

- Superior cooling with low pressure drop
- Extremely Robust design & construction
- Modular design can be configured to application
- Provides cooling at all speeds
- Compact unit can be mounted anywhere for better aerodynamics
- No oil thermostat required

EC/ECD54 Fluid Connection Sizes:

Water connection - Push-on 1.00" (24mm), 1.10" (28mm), 1.25" (32mm), 1.37" (35mm), 1.50" (38mm), 1.75" (45mm) and 2.00" (50mm) **-AN Male:** -12AN, -16AN

Oil connection: (-AN/JIC): -8AN, -10AN, -12AN, -16AN

E54 Pricing: 01/17

single core:

EC54-182 \$660.00

EC54-250 \$695.00

EC54-329 \$765.00

dual core:

ECD54-182 \$760.00

ECD54-250 \$795.00

ECD54-329 \$875.00

price includes (1) assembled unit with choice of water and oil connections. Coolers are built to order and require 7-10 day delivery.

Click text in [BLUE](#) for technical drawing.



ECD54 Engine/Transmission Coolers

These dual coolers combine a larger engine oil cooler with a smaller cooler, that can be used for transmission or differential cooling. Coolers use the ECD double cores with two separate oil circuits and one shared coolant circuit. Available in 271mm and 321mm length. Units are modular and can be built in a variety of configurations from the selection of fluid connections options below.



- ECD54-271 Combined Cooler \$1010.00**
- ECD54-321 Combined Cooler \$1065.00**

Click text in [BLUE](#) for technical drawing.

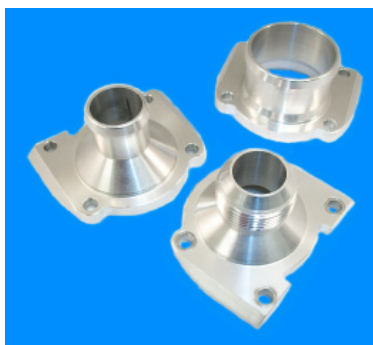

E54 water side fittings

E54 Series Water Side Fittings (each)

- WC00180** 25mm (1.0") O.D. push-on hose **\$79.50**
- WC00152** 28mm (1.10") O.D. push-on hose **\$79.50**
- WC00156** 32mm (1.25") O.D. push-on hose **\$79.50**
- WC00177** 35mm (1.38") O.D. push-on hose **\$79.50**
- WC00179** 38mm (1.50") O.D. push-on hose **\$79.50**
- WC00134** 45mm (1.77") O.D. push-on hose **\$79.50**
- WC00172** 50mm (2.0") O.D. push-on hose **\$79.50**
- WC00182** (-12AN/JIC) thread-on **\$93.80**
- WC00183** (-16AN/JIC) thread-on **\$93.80**



E54 oil side fittings

E54 Series Oil Side Fittings (each)

- OC00078** -8AN fitting for thread-on hose ends **\$49.50**
- OC00070** -10AN fitting for thread-on hose ends **\$49.50**
- OC00060** -12AN fitting for thread-on hose ends **\$49.50**
- OC00055** -16AN fitting for thread-on hose ends **\$49.50**



E54 water restrictors

E54 Series Water Restrictor & Plug (each)

- TB00080** 2mm hole for EC54 single core **\$14.50**
- TB00102** 14mm hole for EC54 single core **\$15.40**
- TB00175** 2mm hole for ECD54 dual core **\$6.95**
- TB00207** 9mm hole for ECD54 dual core **\$8.80**

Restrictors can be used to adjust overall cooler efficiency by regulating water flow to the core. Factors such as; water flow & temperature, oil flow & temperature, oil viscosity & volume, engine rpm, water radiator size & efficiency will also determine overall cooler performance.



E54 gasket, seal & hardware kit

E54 Gaskets, O-rings & Hardware (each)

- TB00267** oil side retaining M6x12 screw (4x required) **\$1.45**
- TB00266** water side retaining M6x25 screw (8x required) **\$1.50**
- SL00083** 26.7mm O-ring for oil side fittings (2x required) **\$3.00**
- SL00084** 44.3mm O-ring for water side fittings (2x required) **\$1.95**
- SL00081** gasket between housing & water side ends (2x required) **\$13.20**
- UA00003*** kit with all gaskets, o-rings & screws **\$52.50**

**enough components to build one E54 cooler*

Laminova Cores and Housings

If required, we can supply new cores and housings for C43 and E54 series coolers. As cores are difficult to clean properly it is recommended they be replaced if metal or bearing material is passes through the cooler. Housings are available in all standard sizes. Some for the C43 series have offset (diagonally) or same side (at one end) oil connections.

C43 Series Cores

CR00005 oil cooler core for C43-90	\$139.80
CR00002 oil cooler core for C43-180	\$169.40
CR00011 oil cooler core for C43-330	\$233.20

EC54 Series Cores

CR00251 oil cooler core for EC54-182	\$205.75
CR00247 oil cooler core for EC54-250	\$256.00
CR00146 oil cooler core for EC54-329	\$326.70

ECD54 Series Cores

CA00064 oil cooler dual core for ECD54-182	\$415.00
CA00065 oil cooler dual core for ECD54-250	\$435.60
CA00012 oil cooler dual core for ECD54-329	\$450.00



Laminova C43 Housings

HS00001 oil cooler housing for C43-90	\$30.00
HS00003 oil cooler housing for C43-180	\$37.50
HS10062 oil cooler housing for C43-180 (OFFSET OIL)	\$46.20
HS00005 oil cooler housing for C43-330	\$49.80
HS10022 oil cooler housing for C43-330 (OFFSET OIL)	\$66.00
HS10136 oil cooler housing for C43-330 (SAME END OIL)	\$66.00

Laminova EC54 / ECD54 Housings

HS00157 oil cooler housing for EC/ECD54-182	\$82.60
HS00188 oil cooler housing for EC/ECD54-250	\$93.50
HS00138 oil cooler housing for EC/ECD54-329	\$99.25

C43 Oil Side Banjo Components

Flanges are available in M14 and M16 for use with a variety of banjo sizes which are especially good in low clearance applications. Parts listed are sold each.

LOC-M14 M14 x 1.5 female flange for C43 cooler	\$38.00
LOC-M16 M16 x 1.5 female flange for C43 cooler	\$38.00
BJBM14 M14 x 1.5 banjo Bolt	\$9.30
BJBM16 M16 x 1.5 banjo Bolt	\$9.30
BJ146M banjo M14 x -6AN male	\$14.10
BJ166M banjo M16 x -6AN male	\$15.75
BJ148M banjo M14 x -8AN male	\$14.10
BJ168M banjo M16 x -8AN male	\$17.20
CWM14 M14 alloy washer	.30
CWM16 M16 alloy washer	.45





NEW

43 Series 3/4" NPT Female Water Connection

This versatile water connection end flange for the 43 series oil coolers permits use of common 3/4" NPT pipe unions and adaptors. This allows a variety of options for using -12 or -10 male connections in straight or 45° and 90° elbows (not included in water connection flange price). These are available as retro-fit for existing installations or as a build option on new coolers ordered.

3/4" NPTF Water Flange for 43 Series Cooler

LWC-N75
\$39.60 each

ECD54-92 Oil Cooler

This is the latest, and smallest (shortest) of the E54 series cooler. The performance falls halfway between the popular 43 series 180mm and 330mm length coolers. For space limited applications this dual core unit is about the same length as shortest/smallest 43 series cooler, the 43-90. If you need the maximum amount of cooling but are space limited in length, this is the cooler to choose.

ECD54-95 \$695.00

price includes (1) assembled unit with choice of water and oil connections. Coolers are built to order and require 7-10 day delivery.



NEW

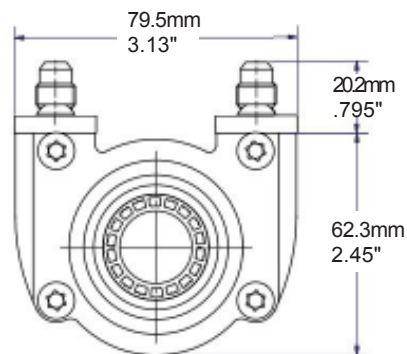
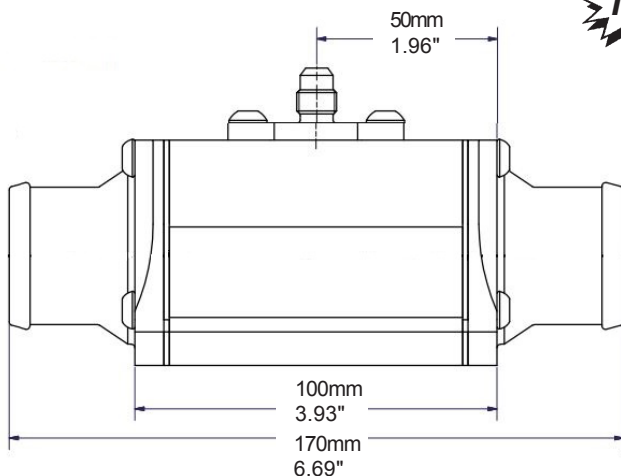

ECDC54 Fluid Connection Sizes:

Water connection - Push-on 1.00" (24mm), 1.10" (28mm), 1.25" (32mm), 1.37" (35mm), 1.50" (38mm), 1.75" (45mm) and 2.00" (50mm) **-AN Male:** -12AN, -16AN

Oil connection: (-AN/JIC): -8AN, -10AN, -12AN, -16AN

ECD54 Series Advantages:

- Superior cooling with low pressure drop
- Extremely Robust design & construction
- Modular design can be configured to application
- Provides cooling at all speeds
- Compact unit can be mounted anywhere for better aerodynamics
- No oil thermostat required